

Washer extractor

W455H

Features and benefits

- **Compass Control®** microprocessor offers:
 - Large display and one dial for easy program selection
 - Language selection
 - Two Quick Start buttons for frequently used wash programs
 - Wash program packages optimized on *Economy, Performance and Time*
- AWS – Automatic Weighing System with Compass Control – determine the wash load and adopt the water intake accordingly. Savings on water and energy if machine is not fully loaded
- Extremely low water and energy consumption – see table below
- Four compartment soap box for manual dosing of powder or liquid detergent
- High extraction force for efficient dewatering
- Door with gasket and strong hinges built for heavy duty operation
- Stainless and galvanized steel in all vital parts for high degree of rust protection
- SuperBalance™ guarantees the correct extraction force



Main options

- Automatic liquid detergent supply (optional I/O board)
- Stainless steel front panel
- Connection to payment system or coin meter
- Drain pump
- Stacking kit to install tumble dryer T4130 on top to save space

Main specifications				W455H
Max. capacity		kg/lb		6/13
Drum, volume		litre		53
	diameter	ø mm		452
Extraction		rpm		1300
G-factor				425
Heating alternatives, 230/400V	electricity	kW		4.7
	non-heated			x
Consumption data "Normal 60°C" * (3G01)				
Total time		min		46
Water consumption (cold/hot)		litre		52/9
Energy consumption (motor/heating)*		kWh		0.2/0.35
* Water temperature 15°C cold water and 65°C hot water.				

Certified in accordance with ISO 9001 and ISO 14001.

Electrical connections*			W455H
Heating	Voltage		
El.	230V 1AC 50 Hz	kW(A)	4.8(25)
	230V 3 AC 50 Hz	kW(A)	4.8(20)
	208-240V 3AC 60 Hz	kW(A)	4.8(20)
	400-415V 3N AC 50 Hz	kW(A)	4.7(10)
Non-heated	208-240V 1AC 60 Hz	kW(A)	0.9(10)
	230V 1AC 50 Hz	kW(A)	0.9(10)
Water connections			
Water valves	DN		20
Water pressure		kPa	200-500
Capacity at 300 kPa		l/min	17
Drain valve		Ø mm	50
Draining capacity		l/min	160
Liquid detergent supplies			4
Floor requirements			
Frequency of the dynamic force		Hz	20
Max floor load at extraction		kN	1.02±0.3
Sound levels			
Sound power level (IEC 60704-2-4)		dB(A)	72
Heat emission			
% of installed power, max			5
Shipping data			
	net, kg		99
	crated, kg		109
	boxed, kg		147
Shipping volume	crated, m ³		0.47
Accessories			
Stainless steel fluff collector			x
Stacking kit with tumble dryer			x
Steel base			x
Dimensions in mm			
A	Width		595
B	Depth		680
C	Height		850
D			305
E			660
F			80
G			195
H			60
I			90
K			80
L			650 ± 50
1	Control panel	5	Hot water
2	Soap box	6	Drain, valve
3	Door opening ø255	7	Drain, pump
4	Cold water	8	Electrical connection

Front and side panels in light grey with "Blue Wave" on front panel (RAL 260 70 05, 250 60 30)

* Other voltages available, see installation manual

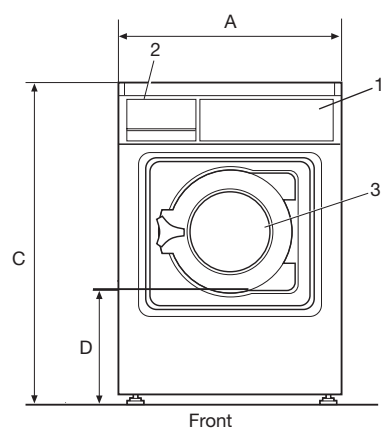

Front

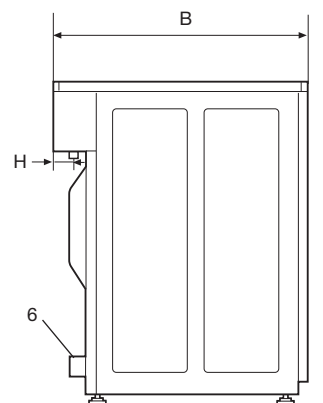

Side view

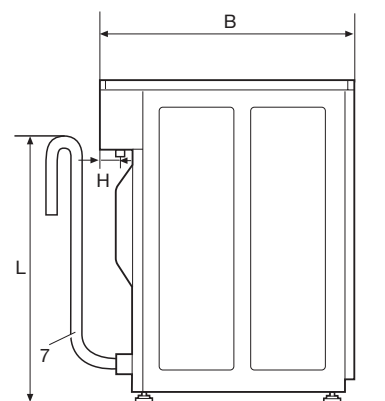

Side view, pump

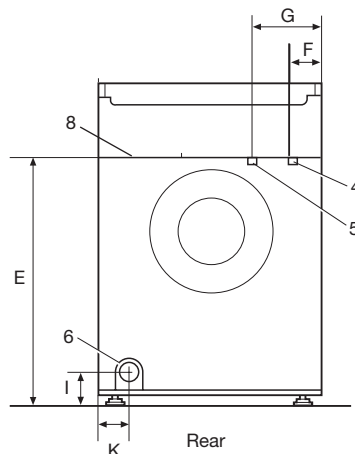

Rear

6206A

Electrolux

www.electrolux.com/professional

Share more of our thinking at www.electrolux.com

Art. No. 471150891/03.07.04
We reserve the right to alter specifications without notice.