

## iQ700, Flex induction cooktop, 30 cm EX375FXB1E

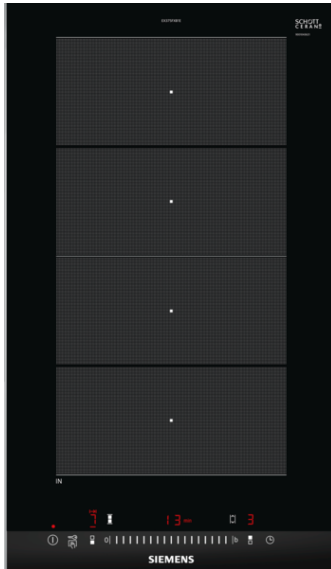

Induction hob with innovative features that enable highly flexible cooking in any situation.

- ✓ flexInduction adapts the cooking zones to different cookware and pots up to 24 cm diameter – for more flexibility.
- ✓ The touchSlider allows the hob temperature to be controlled by entering it directly or by moving the slider with a single finger.
- ✓ powerMove Plus enables intuitive control thanks to three heating zones with different temperatures, just by moving the pan
- ✓ Shorter heating times with up to 50% more power thanks to the powerBoost function.
- ✓ Timer with cooking zone shut-off function
- ✓ Innovative induction technology is one of the quickest, safest and most efficient methods of cooking.
- ✓ The child safety lock safely prevents unintentional switch-on.
- ✓ flexInduction adapts the cooking zones to different cookware and pots up to 24 cm diameter – for more flexibility.
- ✓ The touchSlider allows the hob temperature to be controlled by entering it directly or by moving the slider with a single finger.
- ✓ powerMove Plus enables intuitive control thanks to three heating zones with different temperatures, just by moving the pan
- ✓ Shorter heating times with up to 50% more power thanks to the powerBoost function.

### Features

#### Technical Data

Product name/family : Vario/Domino cooking zone cera  
 Built-in / Free-standing : CONSTR\_TYPE.Built-in  
 Energy input : Electric  
 Total number of positions that can be used at the same time : 2  
 Required niche size for installation (HxWxD) : 51 x 270 x 490-500  
 Width of the product (mm) : 302  
 Dimensions of the product (mm) : 51 x 302 x 520  
 Dimensions of the packed product (HxWxD) (mm) : 126 x 383 x 597  
 Net weight (kg) : 8.118  
 Gross weight (kg) : 8.7  
 Basic surface material : Ceramic  
 Color of surface : Alu, brushed, Black  
 Approval certificates : AENOR, CE  
 Length of electrical supply cord (cm) : 110  
 EAN code : 4242003697405  
 Electrical connection rating (W) : 3700  
 Voltage (V) : 220-240  
 Frequency (Hz) : 60; 50



### Optional accessories

HZ9SE030	Set of 2 pots and 1 pan
HZ394301	Connecting strip
HZ390522	Griddle Plate
HZ390512	Teppan Yaki (large)
HZ390012	Steaming Rack for Stainless Steel roaste
HZ390011	Stainless Steel roaster with glas lid

## iQ700, Flex induction cooktop, 30 cm EX375FXB1E

### Features

#### Design

- 302 mm
- Stainless Steel side trim with bevelled front edge
- touchSlider

#### Special features

- flexInduction zone
- 2 induction cooking zones
- powerMove plus
- quickStart function
- reStart function
- Timer for all zones Acoustic signal Count up timer
- 17 power levels
- Power boost setting
- Energy Consumption Display

#### Safety Features

- Automatic pan recognition Automatic safety switch off Control panel lock Control panel pause
- 2 stage residual heat indicators
- Main on/off switch

#### Power and size:

- Cooking Zones: 1 x Ø 400 mmx210 mm, 3.3 KW (max. Power levels 3.7 KW) Induction or 2 x Ø 210 mm, 2.2 KW (max. Power levels 3.7 KW) Induction
- Installation set to install 2 Dominos side by side

#### Technical information

- Min. worktop thickness: 16 mm
- Cable included
- Connection cable 110 cm
- Connected load: 3.7 KW

## iQ700, Flex induction cooktop, 30 cm EX375FXB1E

### Dimensioned drawings

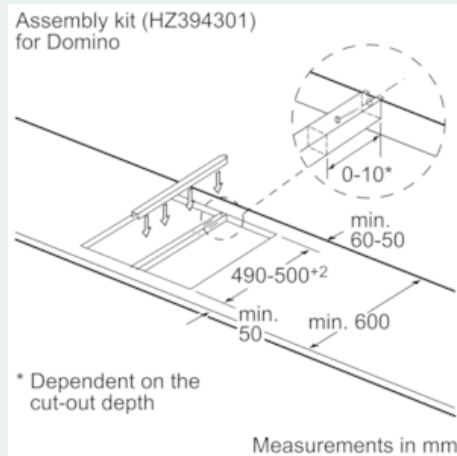
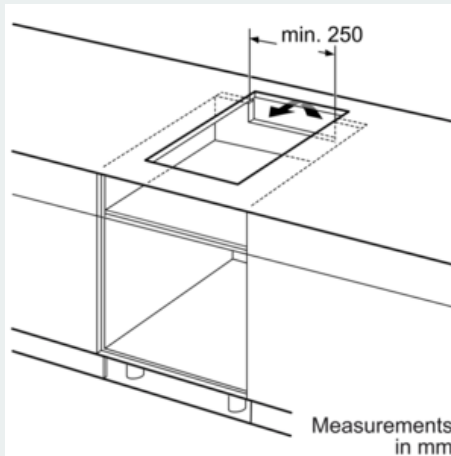
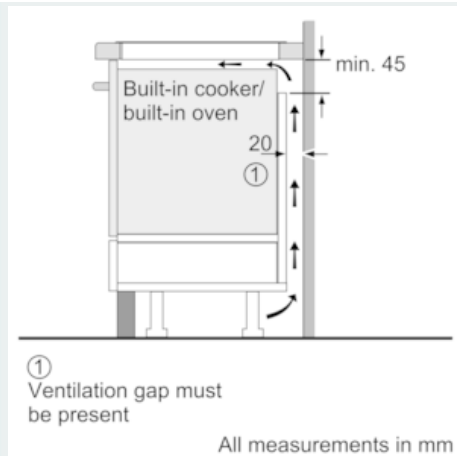
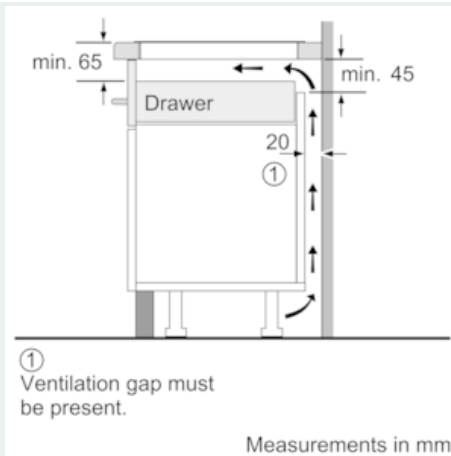

Picture for the table Domino combination possibilities with corresponding devices and cutout dimensions

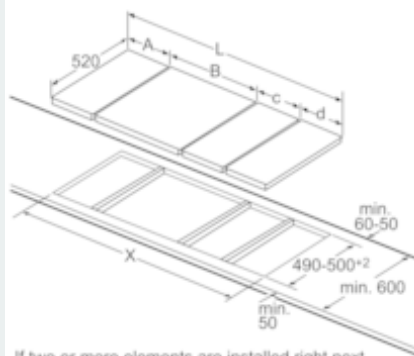

If two or more elements are installed right next to one another, one or several installation kits are required (2 elements 1 installation kit, 3 elements 2 installation kits, etc.).

Cutout dimension (X) depending on the combination see table:

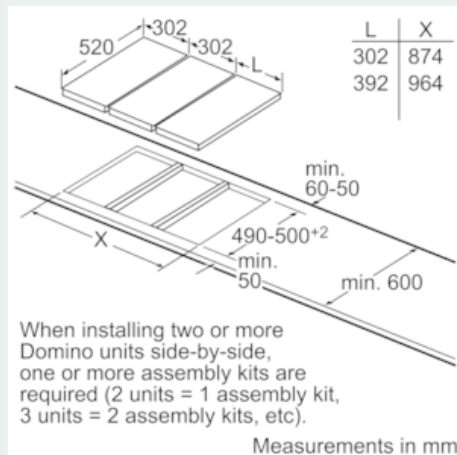

iQ700, Flex induction cooktop, 30 cm  
EX375FXB1E

Dimensioned drawings

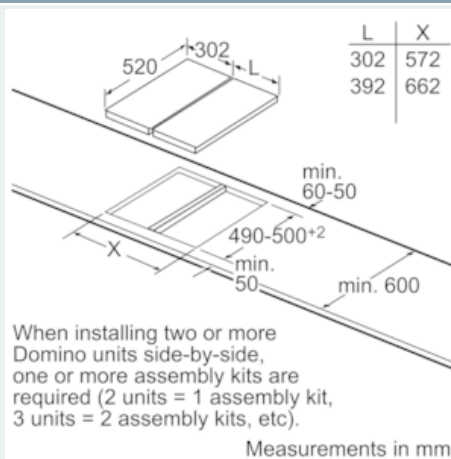

measurements in mm  
Domino combination options with corresponding appliance and cut-out dimensions

Width category: 30 40 60 70 80 90  
Appliance width: 302 392 602 710 812 912

	A	B	C	D	L	X
2x30	302	302	-	-	604	572
1x30, 1x40	302	392	-	-	694	662
1x30, 1x60	302	602	-	-	904	872
1x30, 1x70*	302	710	-	-	1012	980
1x30, 1x80	302	812	-	-	1114	1082
1x30, 1x90	302	912	-	-	1214	1182
2x40	392	392	-	-	784	752
1x40, 1x60	392	602	-	-	994	962
1x40, 1x70*	392	710	-	-	1102	1070
1x40, 1x80	392	812	-	-	1204	1172
1x40, 1x90	392	912	-	-	1304	1272
3x30	302	302	302	-	906	874
2x30, 1x40	302	302	392	-	996	964
2x30, 1x60	302	302	602	-	1206	1174
2x30, 1x70*	302	302	710	-	1314	1282
2x30, 1x80	302	302	812	-	1416	1384
2x30, 1x90	302	302	912	-	1516	1484
1x30, 2x40	302	392	392	-	1086	1054
1x30, 1x40, 1x60	302	392	602	-	1286	1264
1x30, 1x40, 1x70*	302	392	710	-	1404	1372
1x30, 1x40, 1x80	302	392	812	-	1506	1474
1x30, 1x40, 1x90	302	392	912	-	1606	1574
3x40	392	392	392	-	1176	1144
2x40, 1x60	392	392	602	-	1386	1354
4x30	302	302	302	302	1208	1176
3x30, 1x40	302	302	302	392	1298	1266
2x30, 2x40	302	302	392	392	1388	1356
1x30, 3x40	302	392	392	392	1478	1446

