

A2PY-8

100cm "Opera" Pyrolytic Dual Cavity Cooker with Multifunction Oven and Gas hob, St/steel
Energy rating AB

EAN13: 8017709155162

Special promotion on this model* 5 year guarantee on parts and labour if purchased by 31st December 2017. Models included are A5, A4, A3, A2, and A1. Terms and conditions apply. At selected displaying retailers only. [For full terms and conditions please click here](#)

MAIN OVEN



- 10 functions
- Oven capacity: gross - 68 litres, net - 61 litres
- Analogue LED electronic clock/programmer
- Air cooling system
- Closed door grilling
- Quadruple glazed removable door
- Rotisserie
- Easy clean enamel interior

Pyrolytic cleaning

- Conventional: 0.86 kW/h
- Forced air convection: 0.99 kW/h

AUXILIARY OVEN



- 6 functions
- Oven capacity: gross - 39 litres, net - 33 litres
- Triple glazed removable door
- Air cooling system
- Closed door grilling
- Rotisserie
- Easy clean enamel interior
- Conventional: 0.79 kW/h
- Pull out full width storage drawer beneath the ovens

HOB

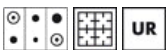

- 6 burners
- Rear left: Ultra rapid 4.20 kW
- Front left: 1.8 kW
- Rear centre: 1.8 kW
- Front centre: 1.00 kW
- Rear right: Rapid 3.00 kW
- Front right: Ultra rapid 4.20 kW
- Heavy duty cast iron pan stands
- Automatic electronic ignition



- Safety valves
- Adaptable for LPG

STANDARD ACCESSORIES:

Main oven:
 Roasting/grill pan
 Grill mesh
 Chrome shelf
 Rotisserie kit

Auxiliary oven:
 Tray
 Grill mesh
 Chrome shelf
 Rotisserie kit

Nominal power: 5.2 kW

- Supply can vary depending on usage, please consult a qualified electrician for ampere requirement

NB: This model supersedes the A2PY-6

Functions

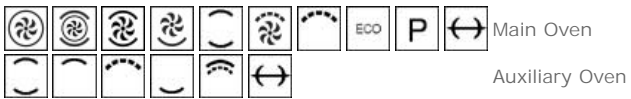

Options

- **PRTX** - Pizza stone with handles
- **KIT1CSP20** - Splashback (Stainless Steel)
- **PALPZ** - Folding Pizza Shovel
- **PR7A2** - Plate Rack (for use in Auxiliary Oven)



Main Oven



Circulaire:

The combination of the fan and circular element around it gives a hot air cooking method. This provides many benefits including no preheat if cook time is more than 20 minutes, no flavour transfer when cooking different foods at the same time, less energy, and shorter cook times. Good for all types of food.



Circulaire with upper and lower elements:

The use of the fan with both elements allows food to be cooked quickly and effectively, ideal for large joints that require thorough cooking. It offers a similar result to rotisserie, moving the heat around the food, instead of moving the food itself, enabling any size or shape to be cooked.



Fan with upper and lower elements:

The elements combined with the fan aim to provide more uniform heat, a similar method to conventional cooking, so pre-heat is required. Most suitable for items requiring slow cooking methods.



FAN WITH LOWER ELEMENT/ CIRCOGAS:

In electric ovens this combination completes cooking more quickly of foods that are ready on the surface, but that require more cooking inside, without further browning. In gas ovens the fan distributes the heat quickly and evenly throughout the oven cavity, avoiding flavour transfer when cooking a number of different dishes at the same time.



Upper and lower element only:

A traditional cooking method best suited for single items located in the centre of the oven. The top of the oven will always be hottest. Ideal for roast, fruit cakes, bread etc.



Fan with grill element:

The fan reduces the fierce heat from the grill, providing an excellent method of grilling various foods, chops, steaks, sausages etc. giving even browning and heat distribution, without drying out the food. The top two levels recommended for use, and the lower part of the oven can be used to keep items warm at the same time, an excellent facility when cooking a grilled breakfast. Half grill (centre portion only) is ideal for small quantities of food.



Grill element:

For rapid cooking and browning of foods. Best results can be obtained by using the top shelf for small items, the lower shelves for larger ones, such as chops or sausages. For half grill heat is generated only at the centre of the element, so is ideal for smaller quantities.



ECO:

The combination of the grill, fan and lower element is particularly suitable for cooking small quantities of food.



Pyrolytic:

Pyrolytic cleaning at 500°C destroys all the dirt deposits inside the oven. The process can be set from 1.5 hours to 3 hours, depending on the degree of dirt build up.



Rotisserie:

The rotisserie (where installed) works in combination with the grill element to brown foods to perfection.

Auxiliary Oven



Upper and lower element only:

A traditional cooking method best suited for single items located in the centre of the oven. The top of the oven will always be hottest. Ideal for roast, fruit cakes, bread etc.



Top element only:

Useful for browning the tops of dishes such as lasagne and potato or cheese topped recipes.



Grill element:

For rapid cooking and browning of foods. Best results can be obtained by using the top shelf for small items, the lower shelves for larger ones, such as chops or sausages. For half grill heat is generated only at the centre of the element, so is ideal for smaller quantities.



Lower heating element only:

Ideal for foods that require extra base temperature without browning, e.g. pastry dishes, pizza. Also suitable for slow cooking of stews and casseroles.



Top element with grill:

Added heat from the top element allows food to be grilled very quickly.



Rotisserie:

The rotisserie (where installed) works in combination with the grill element to brown foods to perfection.



A2PY-8

Opera range
100 cm
stainless steel
hob type: gas
oven type: electric multifunction + electric static
energy rating A+B

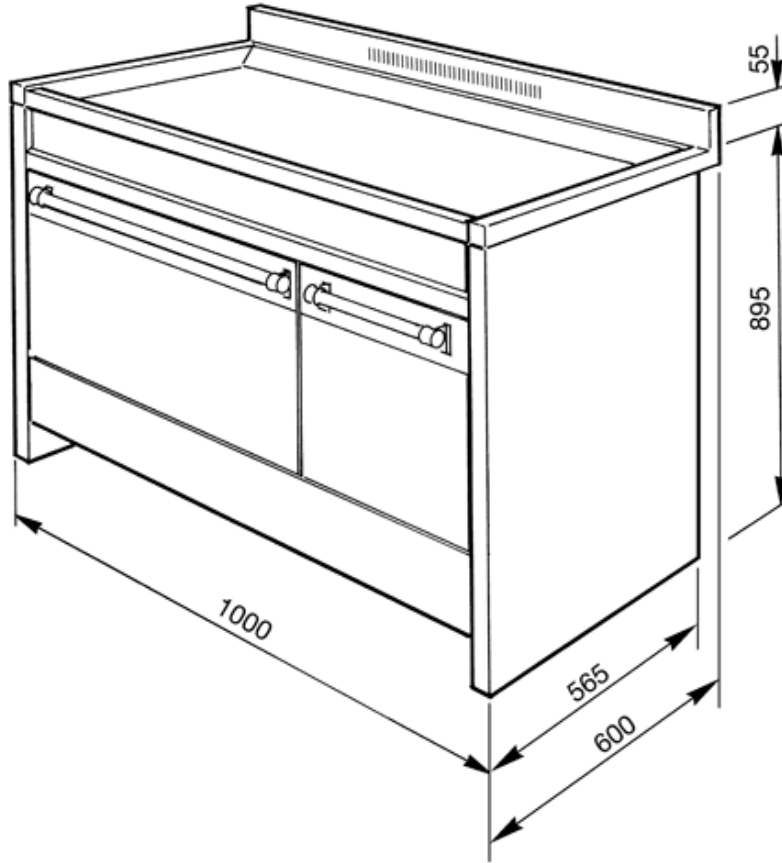

Smeg (UK) Ltd
The Magna Building, Wyndyke Furlong, Abingdon
OX14 1DZ
Tel. +44 (0)844 557 9907
Fax +44 (0)844 557 9337