

50's style Fridge with ice compartment  
in White, Right hand hinge

Energy efficiency class A+  
EAN13: 8017709182717

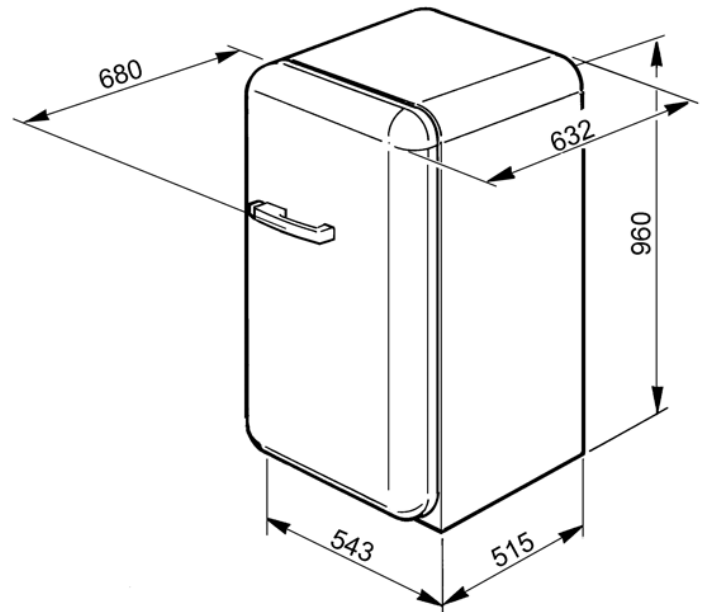

- Gross capacity: 120 litres • Energy consumption: 169 Kw/h per year • Climatic class: SN • Freezing capacity: 2kg/24h • Thaw time: 10h • Refrigerator • Fresh food capacity: 107 litres • Automatic defrost • Adjustable thermostat • 2 adjustable glass shelves • 1 fruit and vegetable drawer • Ice Box (Four stars) • Frozen food capacity: 13 litres • Ice cube tray

## Key to symbols



## Versions

- FAB10LNE - 50's Style refrigerator with ice compartment, Black, LHH • FAB10LR - 50's Style refrigerator with ice compartment, Red, LHH • FAB10LUJ - 50's Style refrigerator with ice compartment, Union Jack, LHH • FAB10RR - 50's Style refrigerator with ice compartment, Red, RHH • FAB10RUJ - 50's Style refrigerator with ice compartment, Union Jack, RRH • FAB10RP - 50's Style refrigerator with ice compartment, Cream, RHH • FAB10LP - 50's Style refrigerator with ice compartment, Cream, LHH • FAB10LO - 50's Style refrigerator with ice compartment, Orange, LHH • FAB10RO - 50's Style refrigerator with ice compartment, Orange, RHH • FAB10RB - 50's Style refrigerator with ice compartment, White, RHH • FAB10LB - 50's Style refrigerator with ice compartment, White, LHH • FAB10RNE - 50's Style refrigerator with ice compartment, Black, RHH