

iQ500
HF15M564B stainless steel
Compact microwave oven

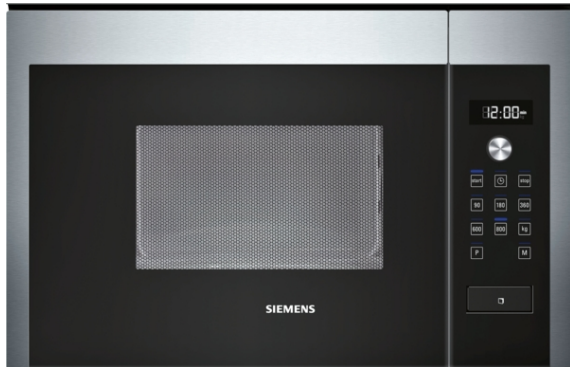

38cm high built-in, frameless microwave for fast defrosting, reheating or preparation of dishes.

- ✓ Perfectly cooked food, everytime, thanks to the electronic cookControl 7 automatic roasting system.
- ✓ lightControl control panel with digital display for easy and intuitive operating convenience.
- ✓ Modern operating convenience thanks to a digital display.
- ✓ Weight control with automatic temperature setting for all defrost, cooking and combination programmes.
- ✓ For installation in a 60 cm wide niche.

Features

Technical Data

Type of micro-wave oven : MW only
Control panel : Electronic
Color / Material Front : Stainless steel
Dimensions of the product (mm) : 382 x 594 x 317
Cavity dimensions (mm) : 201.0 x 308.0 x 282.0
Length of electrical supply cord (cm) : 130
Net weight (kg) : 17.0
Gross weight (kg) : 18.0
EAN code : 4242003658475
Max. microwave power (W) : 800
Connection rating (W) : 1270
Current (A) : 10
Nominal power (kW) : 230-240
Frequency (Hz) : 50
Plug type : GB plug



4 242003 658475

iQ500

HF15M564B stainless steel

Compact microwave oven

Features

Features:

- Left hinged door
- User-friendly electronics with push-buttons and pop-out control.

Comfort:

- 4 weight automatic defrost programmes
- 1 recipe memory setting
- Electronic oven clock timer

Auto

- Maximum microwave power level: 800 W
- 5 microwave power levels
Maximum microwave power level: 800 W

Technical information:

- Installation in 60 cm wide wall unit, Installation in tall housing
- Oven capacity: 20 litres
- 25.5 cm Glass turntable
- Connected load 1.27 kW
- 130 cm power cable: Cable with plug

iQ500
 HF15M564B stainless steel
 Compact microwave oven

Dimensioned drawings

Microwave, corner installation

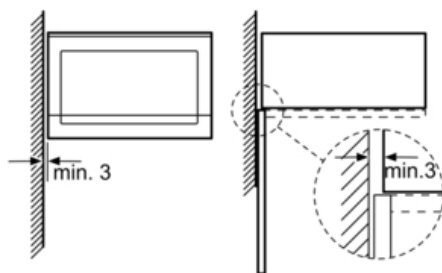

Measurements in mm

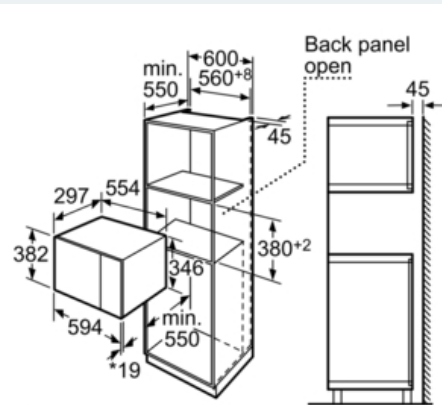

* 20 mm for metal fascias

measurements in mm

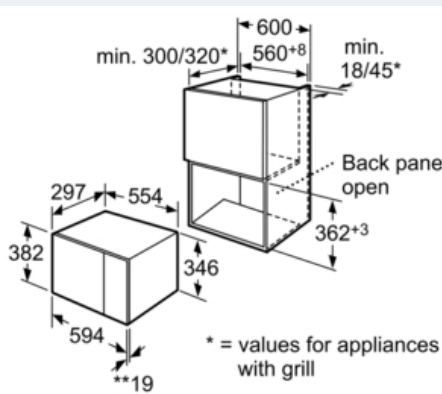

* = values for appliances with grill

** 20 mm for metal fascias

measurements in mm