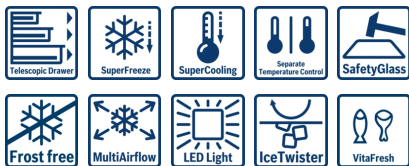

Serie | 8 Side-by-Side
KAN92LB35

**American-style fridge freezer
Glass Black door and chrome
inox metallic side panels.**

A++

**The A++ NoFrost side-by-side fridge-freezer
with indoor electronics: saves you from
defrosting - cools very efficiently.**

- **Energy efficiency class A++:** cools especially efficiently.
- **NoFrost:** never defrost again, thanks to perfect protection from ice formation - that saves time and effort.
- **VitaFresh plus:** keeps food fresh for up to twice as long – thanks to extra low temperatures for fish and meat & optimal humidity for fruit and vegetables
- **Indoor electronics:** modern display in the door - convenient to operate and read from outside.
- **LED Light:** illuminates the refrigerator evenly without glare, for the life of the appliance.

Technical Data

Construction type :	Freestanding
Door panel options :	Not possible
Height (mm) :	1756
Width of the product (mm) :	912
Depth of the product :	732
Net weight (kg) :	140.0
Connection rating (W) :	190
Current (A) :	10
Door hinge :	Left & Right
Voltage (V) :	220-240
Frequency (Hz) :	50-60
Approval certificates :	CE, Eurasian, UA, VDE
Length of electrical supply cord (cm) :	240
Storage Period in Event of Power Failure (h) :	12
Number of compressors :	1
Number of independent cooling systems :	2
Reversible Door Hinge :	No
Number of Adjustable Shelves in fridge compartment (Stck) :	3
Shelves for Bottles :	Yes
EAN code :	4242002818887
Brand :	Bosch
Product name / Commercial code :	KAN92LB35
Energy efficiency :	A++
Energy consumption annual (kWh/annum) - NEW (2010/30/EC) :	385
Refrigerator Net capacity (l) - NEW (2010/30/EC) :	375
Freezer Net capacity (l) - NEW (2010/30/EC) :	217
Frost free system :	Fridge and freezer
Temperature rise time (h) :	12
Freezing capacity (kg/24h) - NEW (2010/30/EC) :	12
Climate class :	SN-T
Noise level (dB) :	43
Installation typology :	N/A

Included accessories

- 2 x cold accumulator
- 1 x egg tray



4 242002 818887

Serie | 8 Side-by-Side

KAN92LB35

American-style fridge freezer Glass Black door and chrome inox metallic side panels.

The A++ NoFrost side-by-side fridge-freezer with indoor electronics: saves you from defrosting - cools very efficiently.

Performance

- Energy efficiency class: A++ (385 kWh per year). Actual consumption will depend on how the appliance is used and where it is located.
- Total net capacity: 592 litres
- Net fridge capacity: 375 litres
- Noise level dB(A) re 1 pW: 43
- Climate class SN-T (suitable for ambient temperatures between 10 to 43°C)

Design features

- Glass Black door and chrome inox metallic side panels.
- Integrated vertical handle
- Interior design with metal applications
- No Frost
- Automatic defrost fridge
- Two separate cooling circuits allow independent temperature control and prevents the transference of humidity between the fridge and freezer cavity
- Bright interior LED fridge light
- Removable magnetic door seals - easy to clean
- Optical and acoustical
- Freezer malfunction warning signal: optical and acoustical

Freshness System

- MultiAirflow system - improves circulation of air around the fridge
- Freezing capacity in 24 hours: 12 kg

Additional features

- 4 removable safety glass shelves of which 3 are height adjustable.
Extendable glass shelf
1 EasyLift glass shelf
1 wire bottle rack
- Maximum freezer storage time in power failure: 12 hours
- Left hinged, Right hinged door
- Height adjustable front feet

Functions

- Separate, electronic temperature control with LED display
- SuperCool function with automatic deactivation
- SuperFreezing function with automatic deactivation
- Optical and acoustical
- Freezer malfunction warning signal: optical and acoustical warning system
- Holiday mode - saves energy when you're away a longer period of time
- AirFreshFilter with AntiBacterial filter to reduce odours and bacteria

Key features - Fridge section

- MultiAirflow system - improves circulation of air around the fridge, ChillerBox - recommended storage area for meat and fish
- 1 VitaFresh ◀0°C▶ drawer - Fish and meat stay fresh for longer
VitaFresh Plus container on telescopic rails with humidity control for prolonged food storage,
1 MultiBox drawer on telescopic rails - Transparent drawer with a corrugated bottom, ideal for storing fruits and vegetables.
- Door trays in fridge door: 2 large and 3 small.
- 2 x cold accumulator, 1 x egg tray
- 1 dairy compartment in door
- Bright interior LED fridge light
- Metal bottle rack

Key features - Freezer section

- 2 freezer drawers, drawers on telescopic rails (partially extendable)
- Twist ice dispenser in freezer
- Door trays in freezer door: 5
- To achieve the declared energy consumption, the distanceholders have to be used. As a result, the appliance depth increases by about 3.5 cm. The appliance used without the distance holder is fully functional, but has a slightly higher energy consumption.
- Dimensions: 175.6 cm H x 91.2 cm W x 73.2 cm D

Serie | 8 Side-by-Side

KAN92LB35

American-style fridge freezer
Glass Black door and chrome inox metallic
side panels.

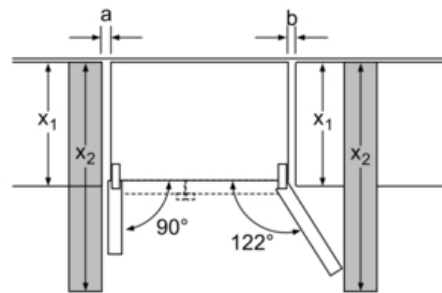
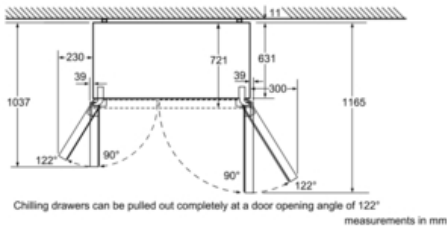

x_1 (unit depth)	a	b
600	39	39
650	39	53
700	39	85
x_2 (wall)	39	300

measurements in mm

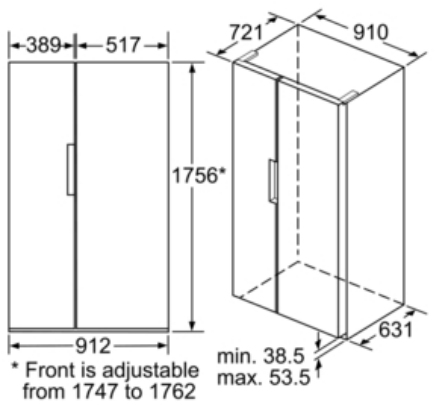

measurements in mm