

SUK92CMX9

90cm "Concert" Cooker with Double Oven and Ceramic hob, Stainless Steel
Energy rating AA

EAN13: 8017709172329

MAIN OVEN



- 7 functions including Circulaire element with fan

Oven capacity: gross - 79 litres, net - 70 litres

- Digital electronic clock/programmer
- Air cooling system
- Closed door grilling
- Removable inner door glasses

Vapor clean

- Conventional (main oven): 0.85kW/h
- Forced air convection (main oven): 0.99kW/h

AUXILIARY OVEN (static oven)



- 4 functions including upper and lower element
- Oven capacity: gross - 39 litres, net - 35 litres
- Air cooling system
- Closed door grilling
- Conventional (auxillary oven): 0.74kW/h

Double storage compartment beneath the ovens

Silver feet and black plinth provided

HOB



- 5 Radiant 'High-Light zones', including 2 dual
- Rear left: Ø 195mm, 2.0 kW
- Front left: Ø 140mm, 1.2 kW
- Central dual zone: Ø 170/265mm, 1.4/2.2 kW
- Rear right dual zone: Ø 140/210mm, 0.75/2.2 kW
- Front right: Ø 140mm, 1.2 kW
- Residual heat indicators
- Automatic safety cut-out

Nominal Power: 13.3 kW

- Supply can vary depending on usage, please consult a qualified electrician for ampere requirement

STANDARD ACCESSORIES:

Main oven:

2 x Roasting/grill pan

Grill mesh

Chrome shelf



Auxiliary oven:

Grill mesh

Chrome shelf

Non-stick tray

Functions



Main Oven



Auxiliary Oven

Options

- **KIT90X** - St/steel splash back
- **PRTX** - Pizza stone with handles
- **PALPZ** - Folding Pizza Shovel
- **PC60** - Stay clean liners for 60 litre cavities
- **PR7A2** - Plate Rack (for use in Auxiliary Oven)

Main Oven



Vapor clean
Vapor clean



Lower heating element only:

Ideal for foods that require extra base temperature without browning, e.g. pastry dishes, pizza. Also suitable for slow cooking of stews and casseroles.

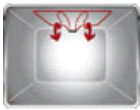

Grill element:

For rapid cooking and browning of foods. Best results can be obtained by using the top shelf for small items, the lower shelves for larger ones, such as chops or sausages. For half grill heat is generated only at the centre of the element, so is ideal for smaller quantities.



FAN WITH LOWER ELEMENT/ CIRCOGAS:

In electric ovens this combination completes cooking more quickly of foods that are ready on the surface, but that require more cooking inside, without further browning. In gas ovens the fan distributes the heat quickly and evenly throughout the oven cavity, avoiding flavour transfer when cooking a number of different dishes at the same time.



Fan with grill element:

The fan reduces the fierce heat from the grill, providing an excellent method of grilling various foods, chops, steaks, sausages etc. giving even browning and heat distribution, without drying out the food. The top two levels recommended for use, and the lower part of the oven can be used to keep items warm at the same time, an excellent facility when cooking a grilled breakfast. Half grill (centre portion only) is ideal for small quantities of food.



Circulaire:

The combination of the fan and circular element around it gives a hot air cooking method. This provides many benefits including no preheat if cook time is more than 20 minutes, no flavour transfer when cooking different foods at the same time, less energy, and shorter cook times. Good for all types of food.



Upper and lower element only:

A traditional cooking method best suited for single items located in the centre of the oven. The top of the oven will always be hottest. Ideal for roast, fruit cakes, bread etc.

Auxiliary Oven



Lower heating element only:

Ideal for foods that require extra base temperature without browning, e.g. pastry dishes, pizza. Also suitable for slow cooking of stews and casseroles.



Grill element:

For rapid cooking and browning of foods. Best results can be obtained by using the top shelf for small items, the lower shelves for larger ones, such as chops or sausages. For half grill heat is generated only at the centre of the element, so is ideal for smaller quantities.

**Half grill:**

For rapid cooking and browning of foods. Best results can be obtained by using the top shelf for small items, the lower shelves for larger ones, such as chops or sausages. For half grill heat is generated only at the centre of the element, so is ideal for smaller quantities.

**Upper and lower element only:**

A traditional cooking method best suited for single items located in the centre of the oven. The top of the oven will always be hottest. Ideal for roast, fruit cakes, bread etc.



SUK92CMX9

Concert range
90 cm
stainless steel
hob type: ceramic
oven type: electric multifunction + electric static
energy rating A+A

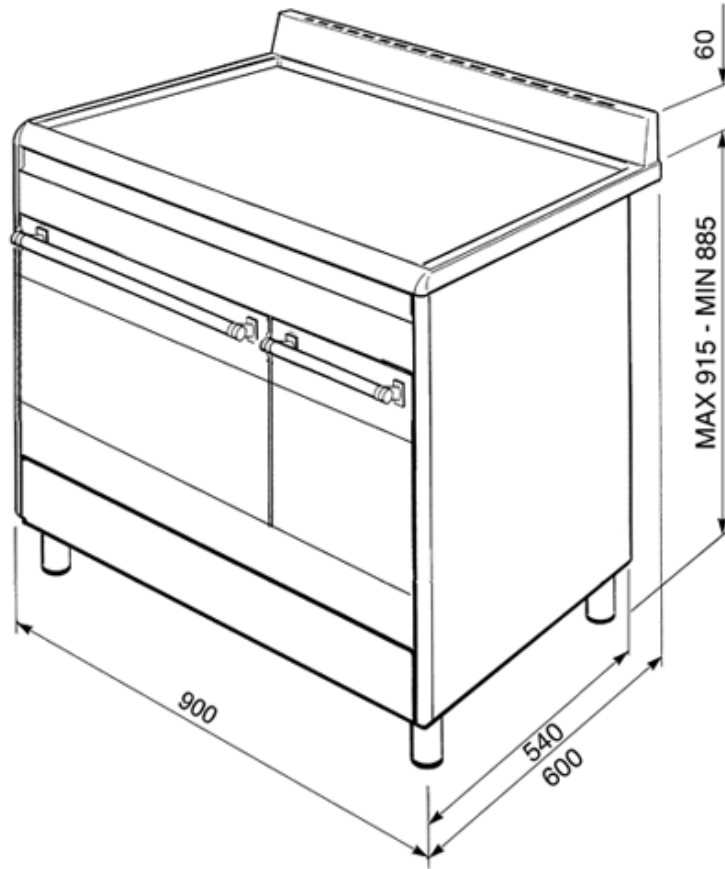

NB: Height with plinth installed is fixed at 900mm

Smeg (UK) Ltd
The Magna Building, Wyndyke Furlong, Abingdon
OX14 1DZ
Tel. +44 (0)844 557 9907
Fax +44 (0)844 557 9337